



  
digital nirvana

Broadcasters and Broadcast Monitors have a variety of needs ranging from compliance logging to repurposing content to selling clips. Digital Nirvana, having years of experience working with the media industry, provides within a single system a vast variety of features, which normally would require multiple systems.

Monitor IQ, a product of Digital Nirvana, simplifies and enhances the ability of Broadcasters and Broadcast Monitors to do a variety of standard business tasks such as monitor, capture, search, report, clip and archive broadcasted content and a plethora of features that enhance reliability of the business, reusability of content and reduces total cost of ownership.



## Content Retrieval & Clipping

The system makes it easy to retrieve content in a variety of ways and protocols. Searching for a particular program is very easy, but as business needs increase, the true power of Monitor IQ gets unleashed! Enhance your content retrieval to new levels:

- ◆ Integrate search results into existing portals using standard XML and HTTP API
- ◆ Key word search (for closed captions), Boolean logic, filter by date and channel, by program name, by dates or by channel.
- ◆ Search on one system or across network.
- ◆ Flexible playback to quickly identify your clip - Jump to a particular spot in playback, fast forward, rewind and use seek within recordings.
- ◆ Access to HD Digital Video recordings/ Physical access to Hi-Res MPEG2 files over MS Windows share, NFS, HTTP, FTP

## High Reliability

Monitor IQ offers rock-solid reliability in terms of hardware that goes into it. The system also takes into account the fact that you can't rewind a broadcast and boasts of a plethora of features that prevent errors and loss of recordings:

- ◆ Automatic switching of key channels to secondary systems if ever a system goes down.
- ◆ System wide intelligent agent sends real time email alerts for recordings, encodings, CC loss, Video (signal loss & blank screen) and system parameters such as processor load, free disk space, free memory, swap space and system services.
- ◆ Redundant storage and redundant power.
- ◆ Reduces number of system components and weak links; Unlike most systems. It has inbuilt tuners which can be set and monitored remotely.
- ◆ Role based user friendly access management permits only authorized users to access administration, settings and content.
- ◆ Automated content management features such as auto expiry and auto archiving ensures most important content is safe and copied to redundant locations.

## Extensible

Monitor IQ's modular 'building block' design allows scaling up your recording and content management capabilities seamlessly. As a networked appliance, Monitor IQ systems are very flexible and can be used to serve all business needs of a single deployment or can be used as a network of multiple systems to monitor dozens and even hundreds of channels.

Features	Standard	Enterprise
Channels per system	2 & 4	4
Redundant Power	Optional	Yes
Advertising & Song Tracking	-	Optional
Video Signal Monitoring	Yes	Yes
System Monitoring & Alerts	Yes	Yes
Redundant Storage	Yes	Yes
Intelligent recording	Yes	Yes
Central captions search	N/A	Yes
Add unlimited systems to network	-	Yes
24x7 one hour block scheduling	Yes	Yes
Import Schedules	Yes	Yes
Customize Encodings	Yes	Yes
Import Encoding settings	Yes	Yes
Preview live recordings	Yes	Yes
Access physical files	Yes	Yes
Cut Clip and download	Yes	Yes
Download videos remotely	Yes	Yes

- ◆ Monitor IQ systems can also be integrated into existing environments to leverage current investments.
- ◆ As systems are added, Monitor IQ allows for individual control of each system and central integration of advanced features such as intelligent recordings, search and downloads.

◆ The enterprise version of Monitor IQ can optionally be loaded with our Repeat Audio Detection system which uses advanced audio finger printing technology to automatically track songs and advertisements. Contact Digital Nirvana for details.

- ◆ The Monitor IQ technical team offers full support in addressing unique challenges of its customers' networks and can customize Monitor IQ integration into most technical and business applications.

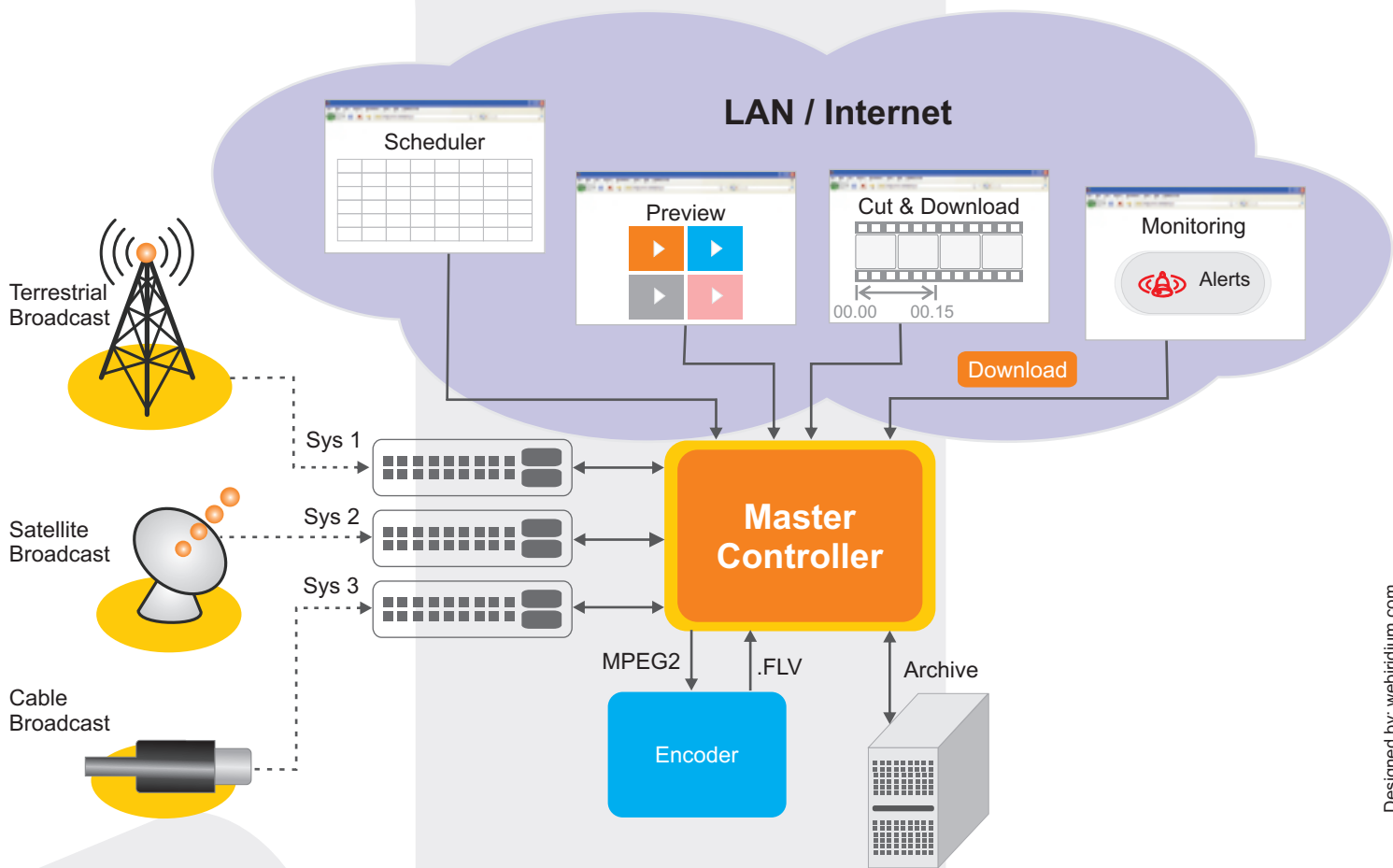

Designed by: webirdium.com

# Monitor

By digital nirvana

For more information, please contact the location nearest you or visit us on the web at: [www.digital-nirvana.com](http://www.digital-nirvana.com)

## Office Locations:

**North & South America**  
 Digital Nirvana, Inc.  
 39899 Balentine Dr,  
 Ste 200  
 Newark, CA 94560  
 Ph: (510) 226 9000  
 Fax: (510) 217 2337

**Europe, Asia & Middle East**  
 Digital Nirvana Information Systems (I) Pvt. Ltd.  
 Plot : 8-2-351/1/11, Navodaya Colony, Road No: 3  
 Banjara Hills, Hyderabad - 500 034  
 A.P. India, Phone: +91 - 40 - 66102777  
 Fax: +91 - 40 - 66736365

